

Maintenance Recommendations:

- Most metal parts should be cleaned and lubricated regularly with a quality gun-grade lubricant
- The Striker, Striker Channel and Striker Block should be clean and dry when assembled. Any lubricant on these components will cause the striker to slow and may cause a failure to ignite the primer

Lubrication Points:

- The barrel needs to be lubricated in the following locations (see above illustration):
 - Muzzle Lockup surfaces (Top & Bottom) from the muzzle back roughly 3/4"
 - Top Lockup Surface in front of the chamber
 - Bottom Lockup surface
- Use any Gun Grade Oil or Grease, lubricants that stay in place are best
- We recommend the frame rails receive lubrication, not the slide rails. See our lubrication video for details
- DO NOT LUBRICATE THE STRIKER CHANNEL OR VENT HOLE

Life Cycle:

- The springs included in your slide are designed by Apex and are rated for 8,000 rounds before replacement
- Replacement spring kits are available at www.ApexTactical.com

Dry Fire:

- We highly recommend using a snap cap when dry-firing your pistol. A snap cap in the chamber absorbs the excess energy from the impact of the striker, which will significantly extend the service life of the striker

Misc:

- Replacing Sights: The dovetails are cut to accept any sights that will fit a Hellcat Pro factory slide

Corrosion Resistance:

- Though the slide and barrel are made of stainless steel, this does not mean they cannot rust. To prevent corrosion, we recommend you occasionally wipe down the slide with oil and properly lubricate the barrel

Optic Mounting:

- Check the specifications from your optic manufacturer for the proper torque on your screws. If no recommendations exist, we recommend all screws be torqued to 15 in-lb (Inch Pounds) MAXIMUM

Apex Tactical Specialties, Inc.

8009 W. Olive Avenue
Peoria, AZ 85345

For assistance contact us at:

623-322-0200
guns@apextactical.com



www.ApexTactical.com



Facebook.com/ApexTactical



Instagram.com/ApexTactical



YouTube.com/ApexTactical

We recommend this product be installed by a competent gunsmith.

Modification of your firearm may nullify the warranty of the firearm manufacturer.

No liability is expressed or implied for damage or injury which may result from improper installation or use of this product.

YOU are responsible for the safe handling, legalities, and correct use of the firearm.

WARNING: Cancer and Reproductive Harm - www.P65Warnings.ca.gov



**APEX SLIDE FOR
HELLCAT AND
HELLCAT PRO**

Apex Slide For Hellcat/Hellcat Pro

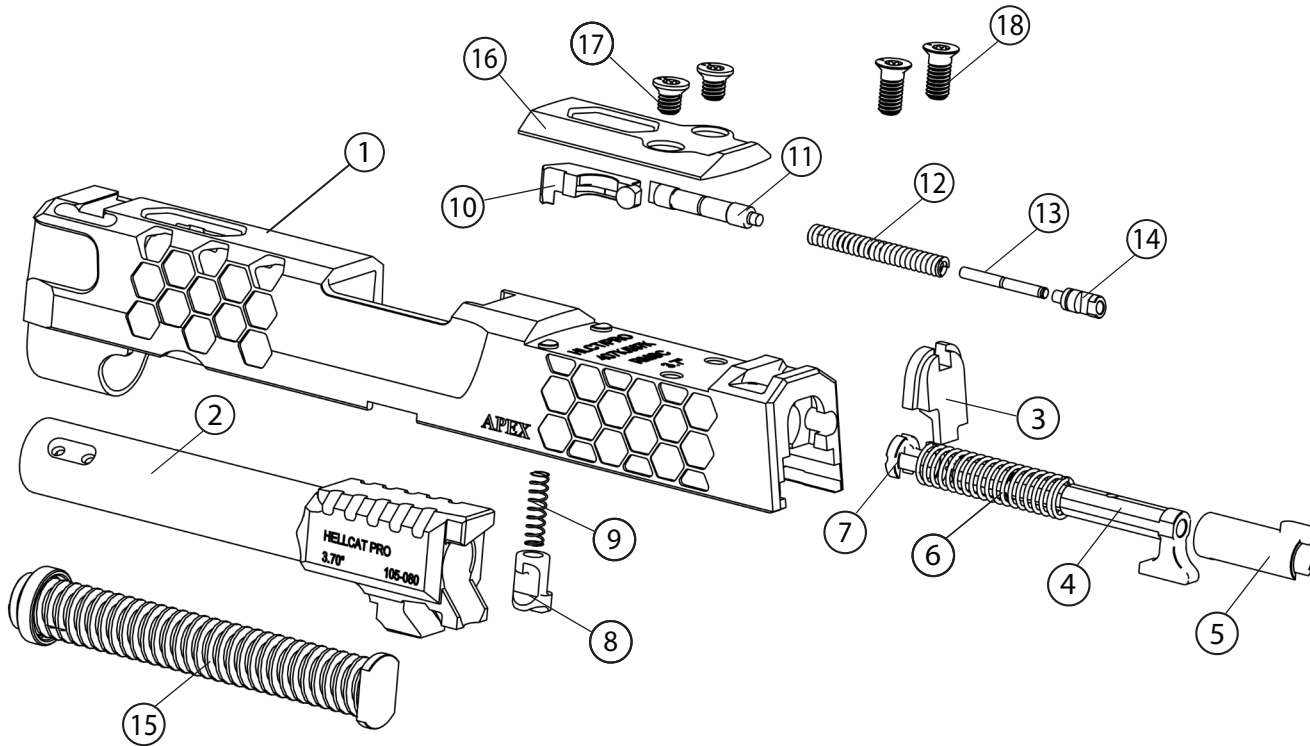

**PROUD TO BE MANUFACTURING
IN THE FREE STATE OF ARIZONA**

Parts Key

		Apex SKU	Factory SKU
1	Slide	Variable	N/A
2	Barrel	105-080	HCP0901TB-KIT
3	Striker Locking Plate	N/A	HC0026
4	Striker	N/A	HC0909
5	Striker Guide	N/A	HC0025
6	Striker Spring	Part of 115-185	HC0911
7	Striker Spring Retainer (2 pc Set)	N/A	HC0030
8	Striker Block	N/A	N/A
9	Striker Block Spring	N/A	N/A
10	Extractor	115-090	HC0934
11	Extractor Pin	Extractor Components Kit 115-194	XDSG0935
12	Extractor Spring		XDSG0033
13	Extractor Spring Pin		XDSG0033P
14	Extractor Spring Plate		XDSG0033PL
15	Recoil Assembly	115-140*	HC0980**
16	OSP Plate	Optic Cover Plate Kit 115- 068	HC5071
17	OSP Screw		XD5070
18	Optic Mounting Screws for Holosun K Cut optics (407K, 507K, EPS, EPS Carry)	SCR-043-SET	N/A
	Rear Sight (not pictured)	Sold as a Set	HC5018OSP
	Front Sight (not pictured)	XS Sights R3D Night Sight	N/A

*Functions in the Hellcat Pro Length Slide only

**Functions in the Classic Hellcat Slide only - Not the PRO